

Optimized for a Smoother ICSI Workflow

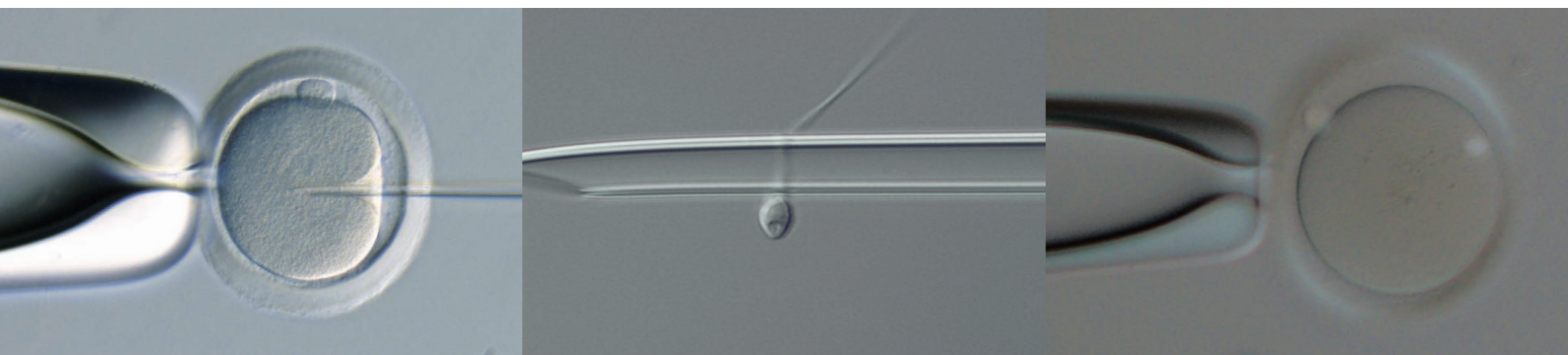

*For Research Use Only.
*Additional 3rd party products shown.

A Fast, Automated Microscope Solution Designed for ICSI

IX73 Microscope: Motorized Observation Method Switching

- Quickly change observation methods by pressing a button on the hand switch
- Spindle observation is standard with a semi-motorized system; IMSI units are available



*Additional 3rd party products shown.

IX83 Microscope: Fully Motorized and Highly Advanced

- Standard configuration supports IMSI and spindle observation
- Quickly change observation methods and magnification using the controller
- Focus position and brightness automatically adjust when you change magnifications
- Easily operate the focus and switch between camera and visual observation using the remote control, reducing sample vibration



*Additional 3rd party products shown.

Observation Methods

ICSI (Intracytoplasmic Sperm Injection)

Olympus' relief-contrast allows the observation of 3-dimensional oocytes in plastic dishes. Relief-contrast observation is used in ICSI to check the condition of oocyte zona pellucida, since it is not affected by the polarizing effect of the plastic dish.



Relief-contrast observation image

IMSI (Intracytoplasmic Morphologically Selected Sperm Injection)

The IMSI method for the injection of morphologically selected sperm into an oocyte is optional on the IX3 systems. Shape, size, and the number of vacuoles in the sperm head can be confirmed using differential interference observation at a high magnification.

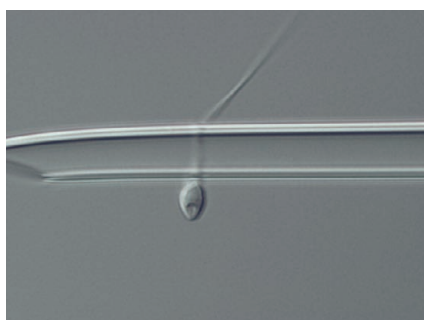

Differential interference observation image

SL-ICSI (Spindle Localization ICSI)

Mature oocytes in metaphase II can be easily confirmed by observing the appearance of the spindle using Olympus' polarizing technology. The spindle does not always locate near the first polar body, so locating it is important to avoid damaging the spindle during injection.



Polarized observation image*

*Sample and image data are courtesy of Dr. Kazuo Uchiyama

Streamlined ICSI with Motorization

- Instantly change observation methods and adjust the magnification with the push of a button thanks to the integrated hand switch remote
- A motorized system can reduce the number of steps in your workflow, improving efficiency and enabling you to focus on the manipulator

*IMSI is also available with an optional unit.

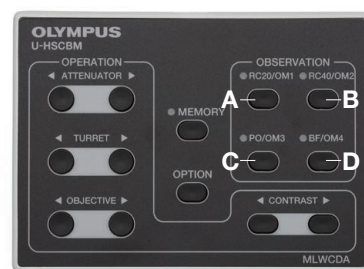

Integrate 2 Steps with 1 Push of a Button

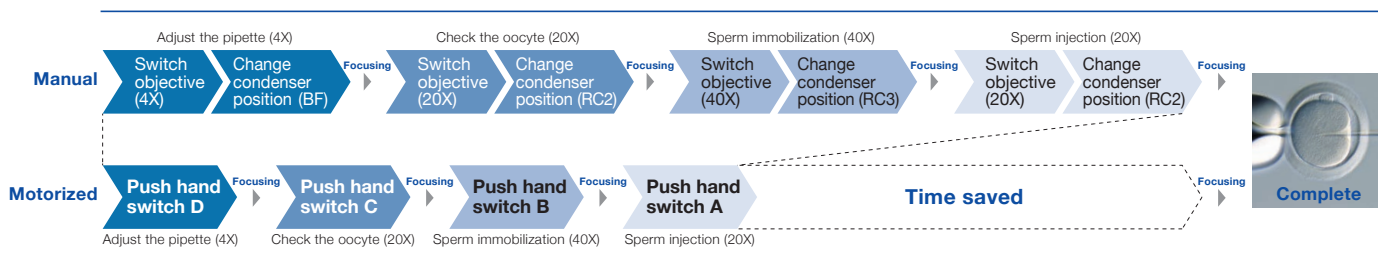

System Diagram

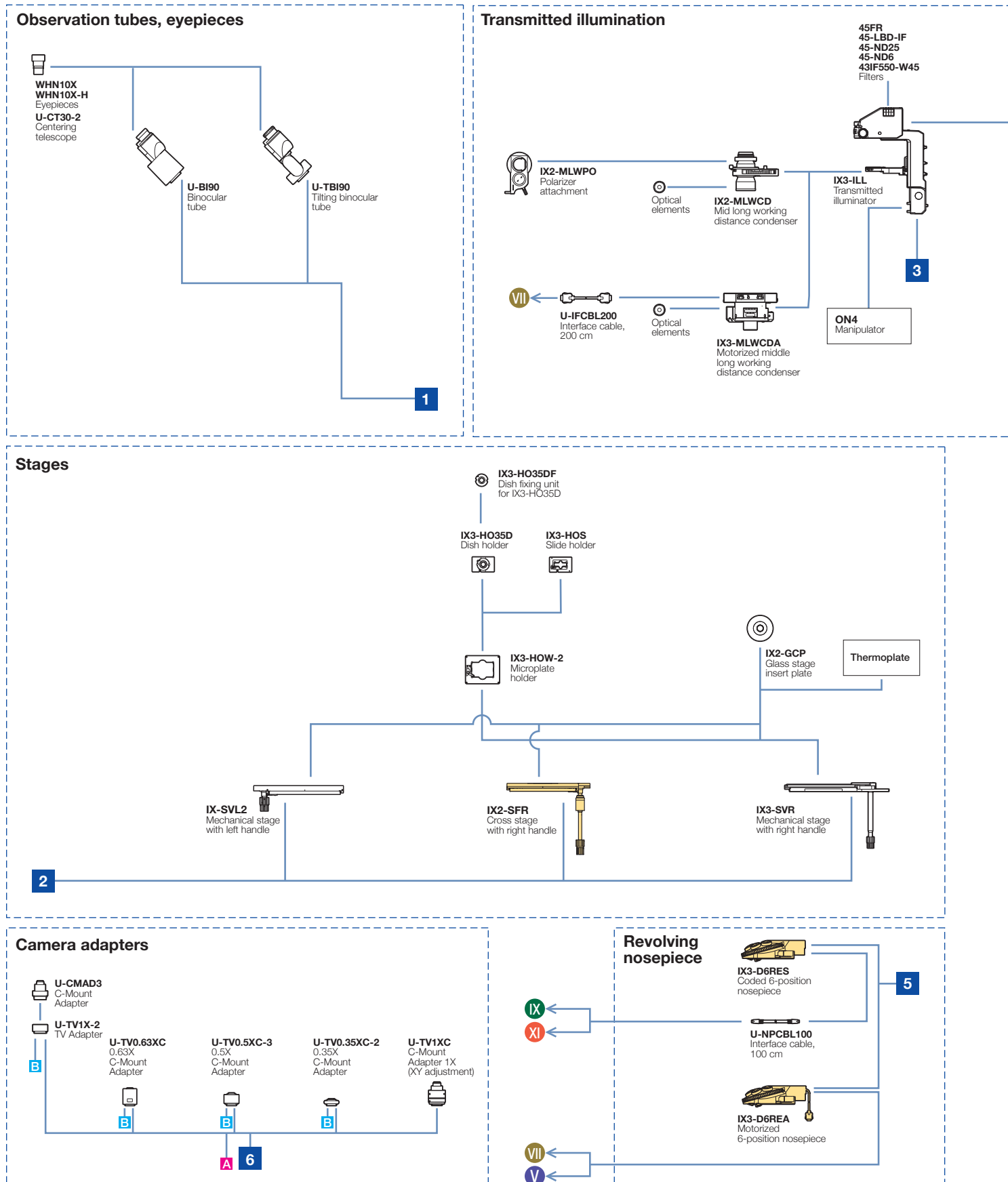

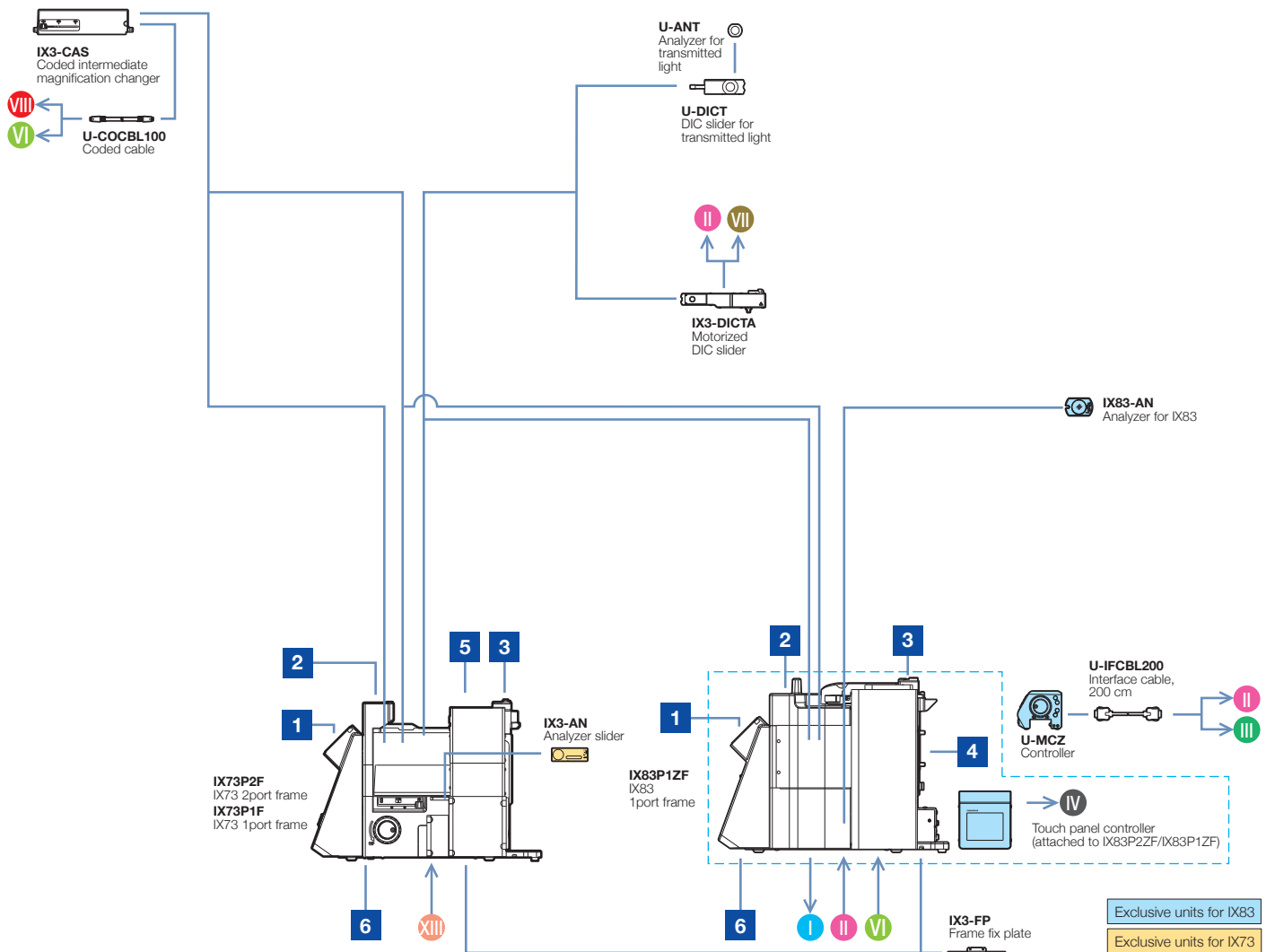
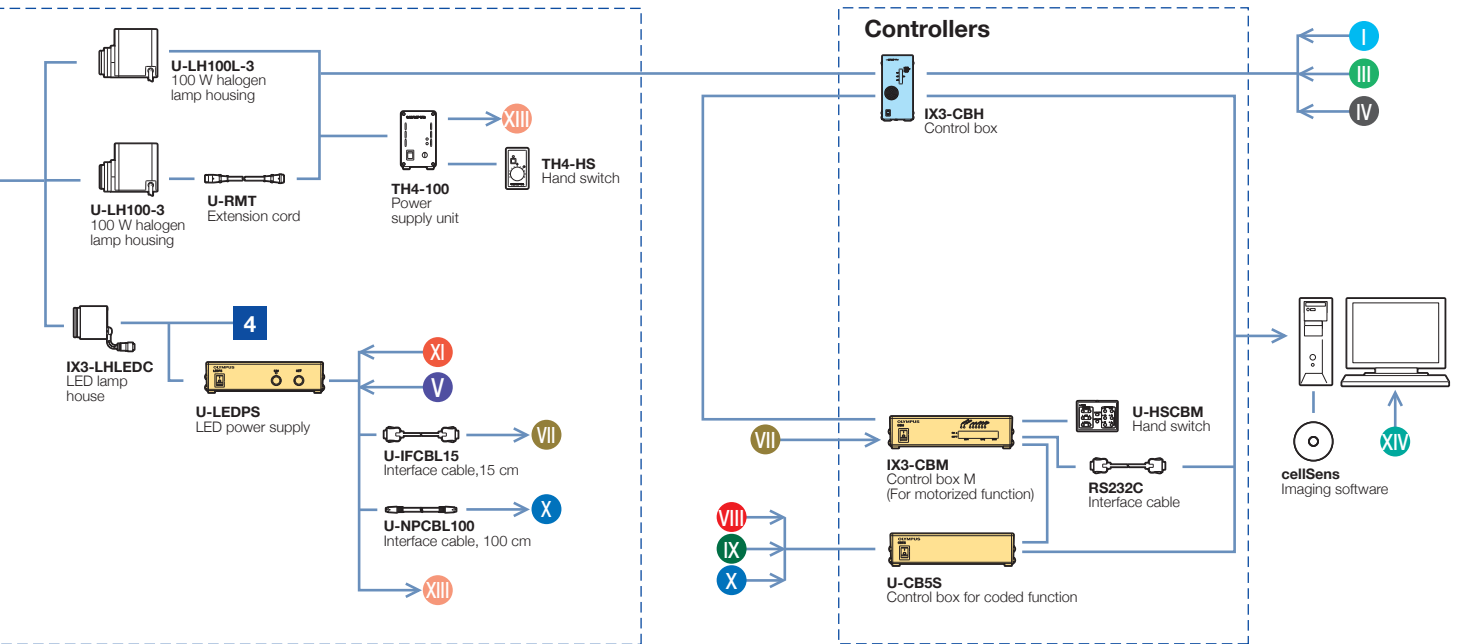

Specifications

		IX83	IX73
Microscope frame	Optical system	UIS2 optical system	
	Revolving nosepiece	<ul style="list-style-type: none"> Motorized sextuple revolving nosepiece (DIC slider attachable), simple waterproof structure 	<ul style="list-style-type: none"> Motorized sextuple revolving nosepiece (DIC slider attachable), simple waterproof structure Coded sextuple revolving nosepiece (DIC slider attachable), simple waterproof structure
	Focus	Stroke: 10.5 mm Minimum increment: 0.01 µm, Maximum nosepiece movement speed: 3 mm/s	Stroke: 10 mm
	Intermediate port	1 port (IX83P1ZF)	2 ports (IX73P2F), 1 port (IX73P1F)
	Light path selection	Motorized 0:100/50:50/100:0 (Left side port: BI port)	Manual 0:100/50:50/100:0 (Left side port: BI port)
Transmitted light illuminator	Pillar tilt mechanism (30 ° inclination angle, with vibration reducing mechanism), Condenser holder (with with 88 mm stroke, refocusing mechanism), Field iris diaphragm adjustable, 4 filter holders Light source: •12 V, 100 W halogen bulb (pre-centered) <ul style="list-style-type: none"> High color reproductive LED light source 		
Observation tube	Widefield (FN 22)	•Widefield tilting binocular •Widefield binocular	
Stage	Mechanical stage with left handle	Stage stroke: X: 50 mm x Y: 43 mm, including stage insert plate (ø25 mm), stage insert plate exchangeable (Ø110 mm)	
	Cross stage with right handle	Stage stroke: X: 50 mm x Y: 50 mm, including stage insert plate (ø25 mm), stage insert plate exchangeable (Ø110 mm)	
	Mechanical stage with right handle	Stage stroke: X: 114 mm x Y: 75 mm, stage position locking function	
Condenser	Motorized middle long working distance condenser	NA 0.5, W.D. 45 mm, 4 positions for optical devices (for ø50 mm, relief contrast optical devices rotatable)	
	Mid long working distance relief contrast	NA 0.5, W.D. 45 mm, 4 positions for optical devices (for ø50 mm, relief contrast optical devices rotatable)	
Operating environment	<ul style="list-style-type: none"> Indoor use Ambient temperature: 5 °to 40 °C (41 ° to 104 °F) Maximum relative humidity: 80% for temperatures up to 31 °C (88 °F), decreasing linearly through 70% at 34 °C (93 °F), 60% at 37 °C (99 °F), to 50% relative humidity at 40 °C (104 °F) Supply voltage fluctuations: Not to exceed ±10% of the normal voltage 		

Combination		IX83 (Motorized)	IX73 (Semi-Motorized)	IX73 (Manual)
Switching of objective magnification and condenser position		Motorized	Motorized	Manual
Observation methods	ICSI (Relief-contrast)	Motorized	Motorized	Manual
	IMSI (Differential interference)	Motorized	Option: Manual	–
	Spindle observation (Polarizing)	Motorized	Motorized	–

Dimensions

(Unit : mm)

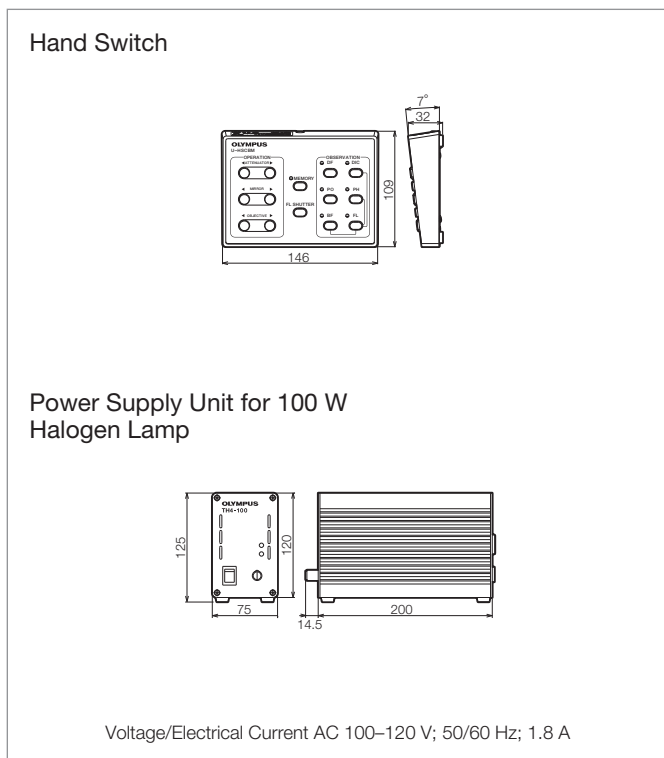
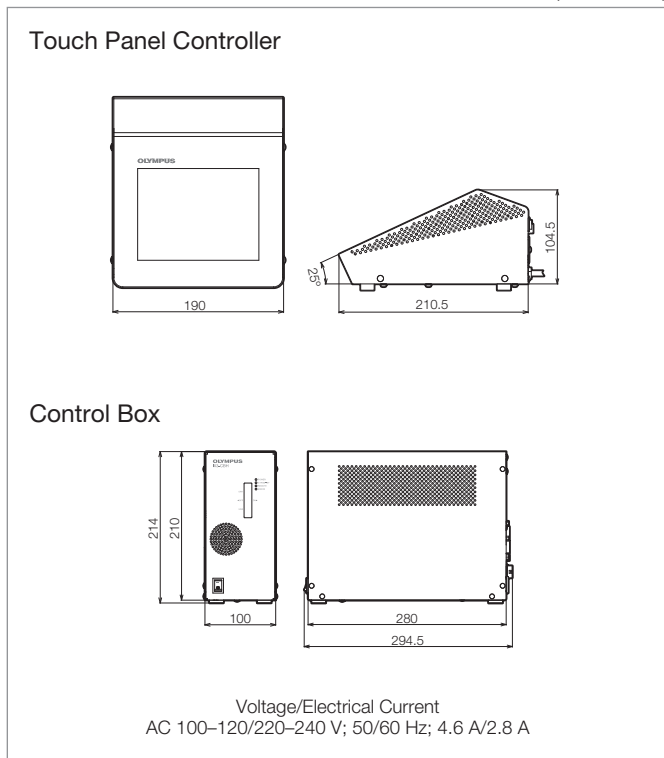
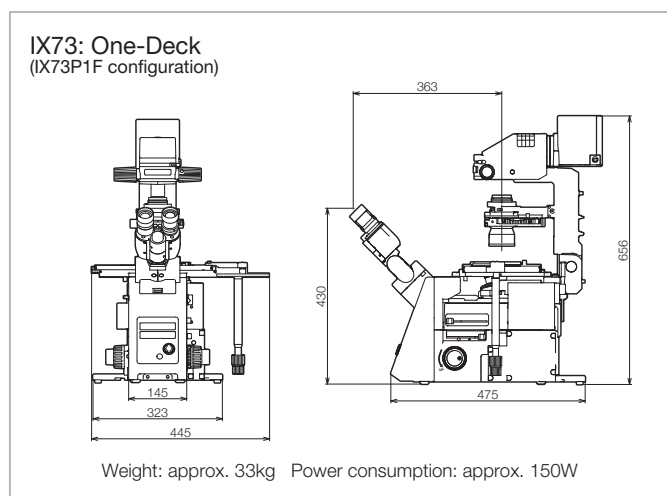
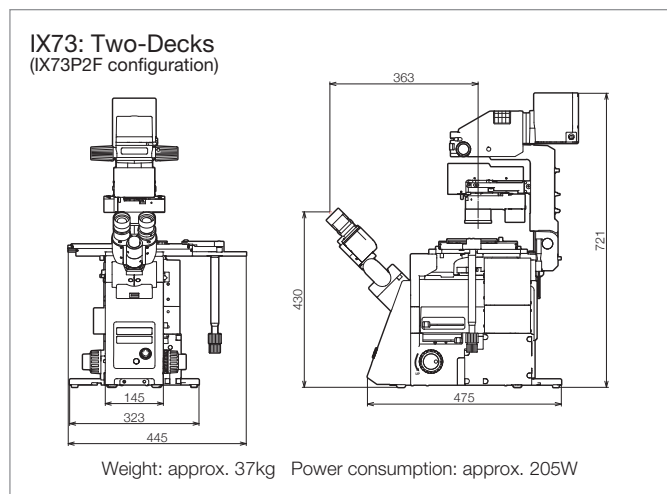
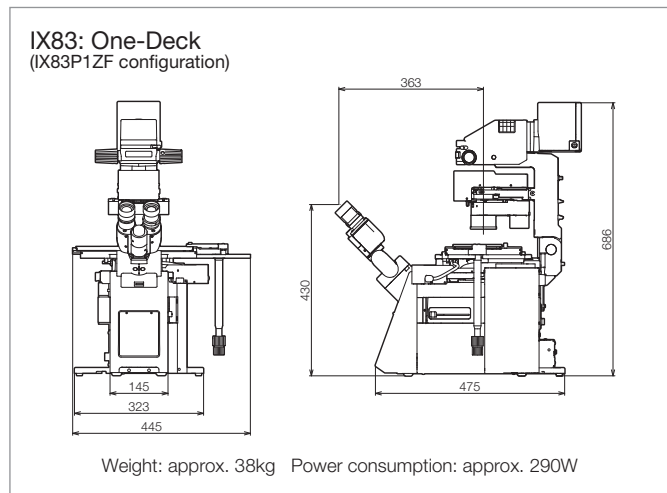

Improve Your IVF Workflow

BX53 Biological Microscope

The microscope's high-luminosity, high-color-rendering LED combined with Olympus' UIS2 infinity-corrected optics enable you to view sperm movement and activity with bright, high-contrast images.

The light source's approximately 50,000-hour lifetime reduces the need for maintenance.

*For Research Use Only.



BX53

SZX16 Stereo Microscope

This stereo microscope features a wide zoom ratio of 1:16.4 and good contrast for oocyte and embryo observation. Its ergonomic design provides less eye fatigue and high operability.

*For Research Use Only.



SZX16 (Base: SZX2-ILLTQ)+DP23

DP23 Digital Color Camera

The DP23 camera has a high frame rate up to 60 fps in full HD, enabling you to comfortably focus and operate the stage while watching the live image. You can easily record images and videos using the stand-alone module or a PC.

*For Research Use Only.



DP23

- EVIDENT CORPORATION is ISO14001 certified.
- EVIDENT CORPORATION is ISO9001 certified.
- Illumination devices for microscope have suggested lifetimes. Periodic inspections are required. Please visit our website for details.
- This product is designed for use in industrial environments for the EMC performance. Using it in a residential environment may affect other equipment in the environment.
- All company and product names are registered trademarks and/or trademarks of their respective owners.
- Images on the PC monitors are simulated.
- Specifications and appearances are subject to change without any notice or obligation on the part of the manufacturer.

EvidentScientific.com



EVIDENT CORPORATION
Shinjuku Monolith, 2-3-1 Nishi-Shinjuku, Shinjuku-ku, Tokyo 163-0910, Japan