

See More Detail at Depth

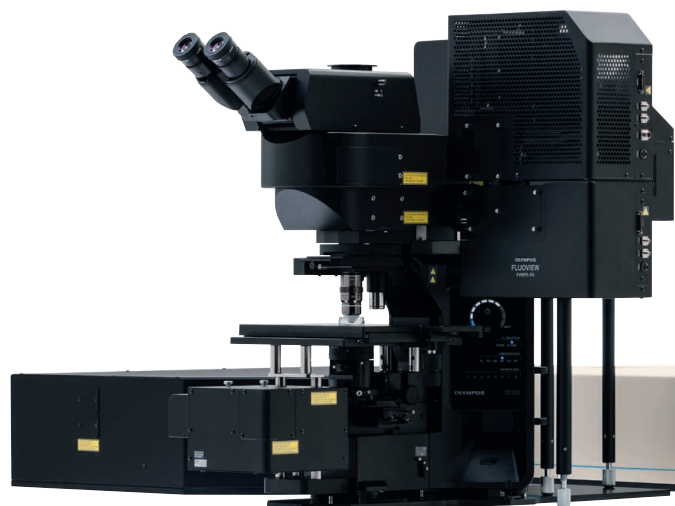

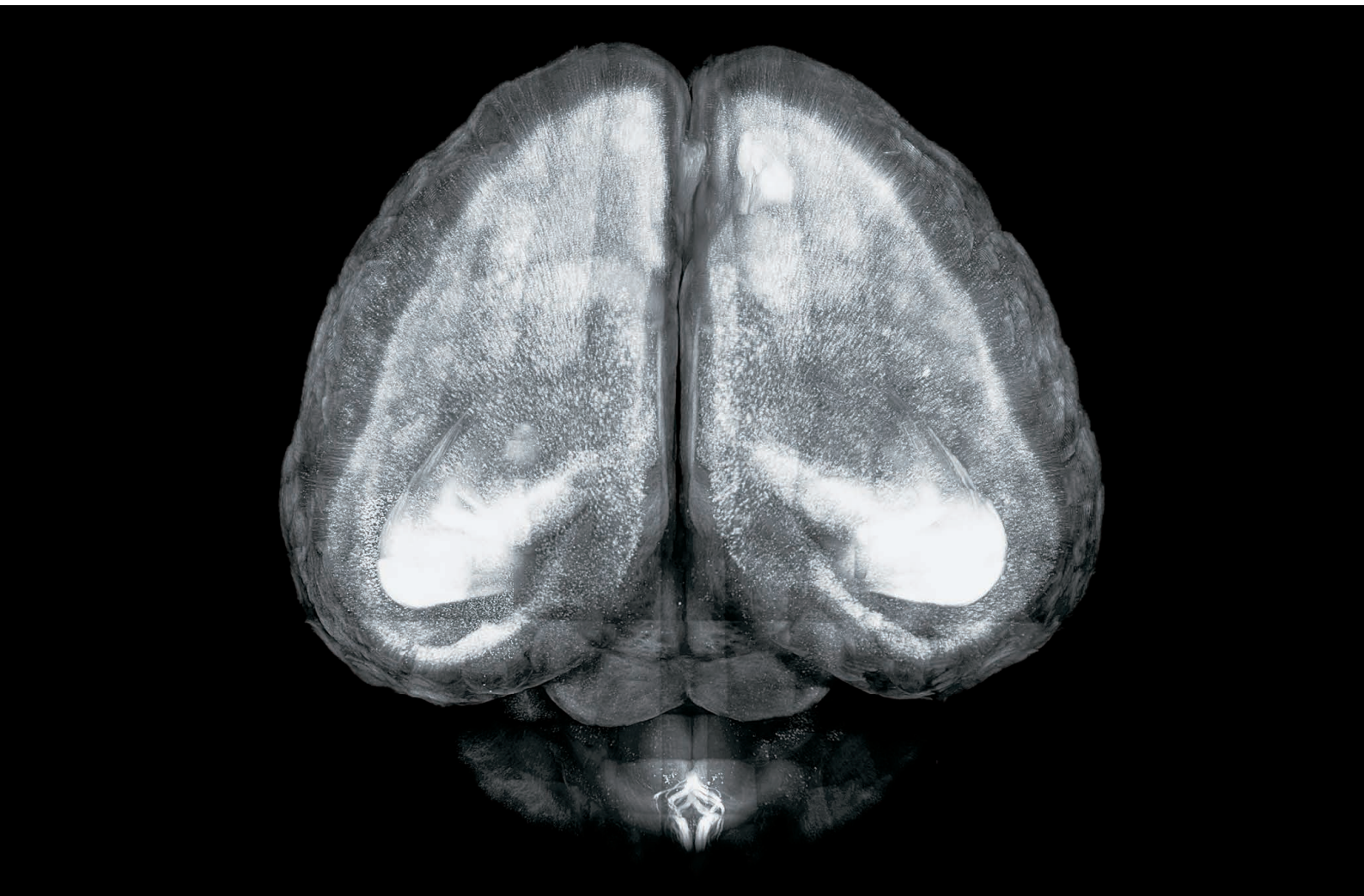
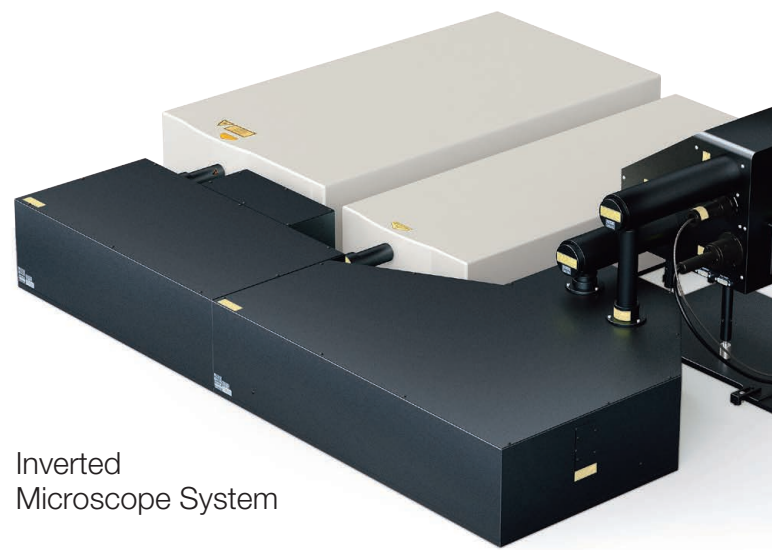
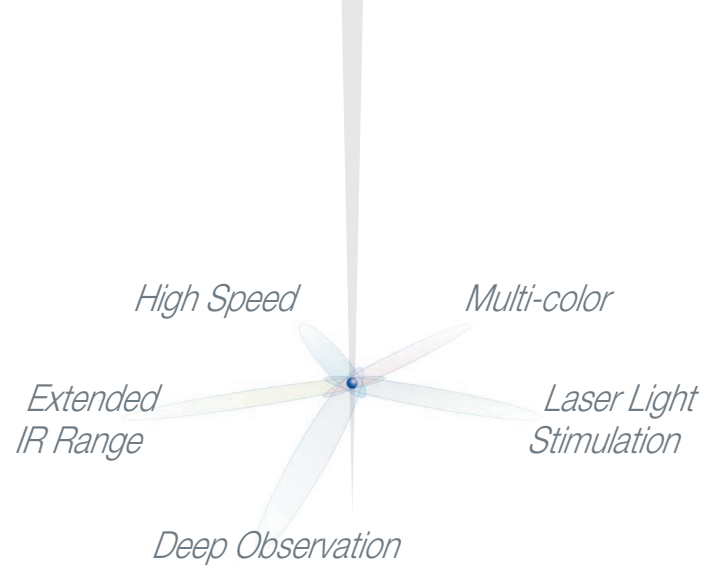

Inverted  
Microscope System

## High-Speed Imaging at Depth

The Olympus FVMPE-RS multiphoton imaging system is purpose-built for deep imaging in biological tissue, aimed at revealing both detail and dynamics. Innovative features for efficient delivery and detection of photons in scattering media enable high signal-to-noise ratio acquisition. This translates to bright images with precise details — even from deep within the specimen. High sensitivity is matched with high-speed imaging to capture rapid *in vivo* responses. For advanced applications, dual-wavelength excitation extending to 1300 nm is available. Independent control of visible or multiphoton laser light stimulation and the ability to synchronize with patch clamp data are also possible.

Multiple configurations are available on the FVMPE-RS platform; each imaging system is customizable to meet your unique research requirements.

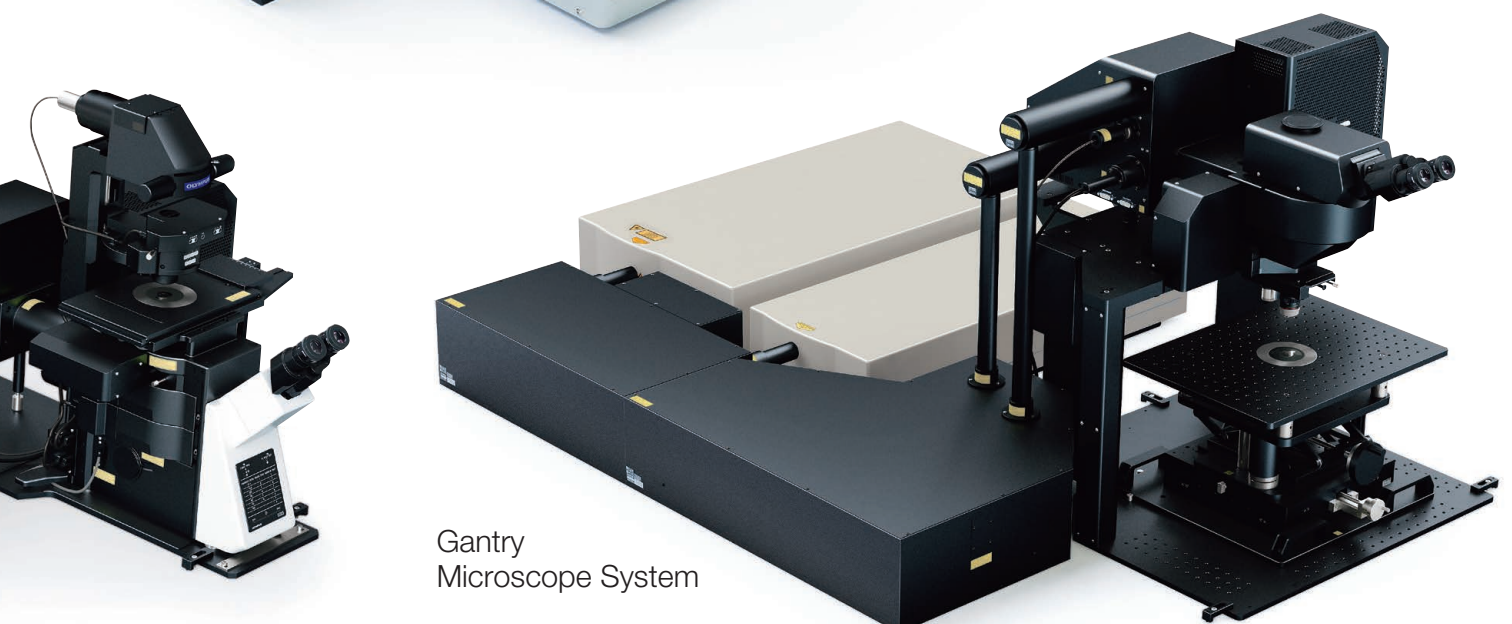
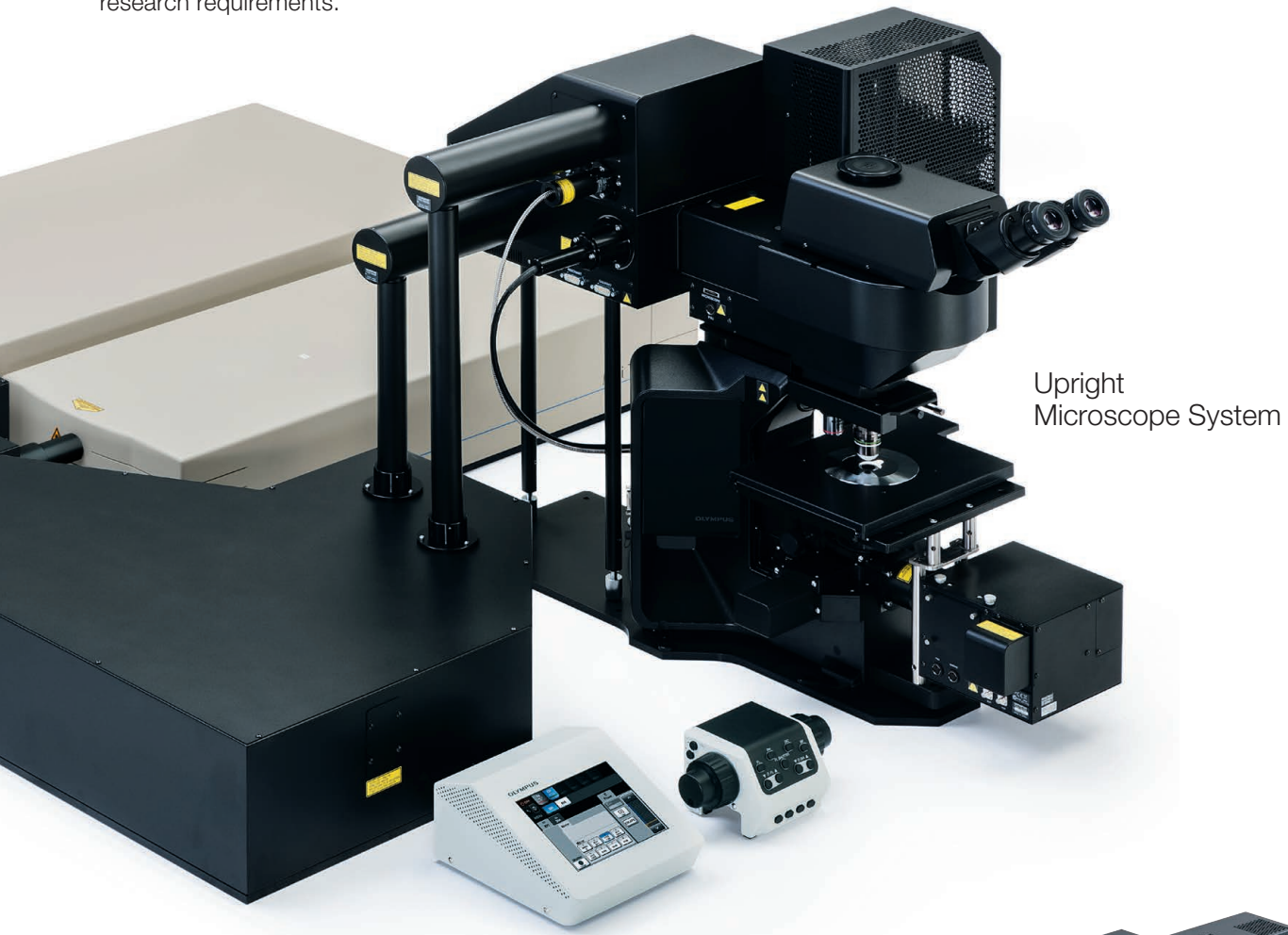

# Designed for Deep Imaging

## Maximize Resolution in Deep Imaging

Olympus TruResolution objectives maximize resolution and contrast for 3D imaging deep within thick specimens. The objectives are equipped with a motorized correction collar that can automatically and dynamically compensate for spherical aberration while maintaining focus position. Refractive index mismatch between the sample and immersion medium introduces spherical aberration that degrades the focus of an objective lens. This aberration worsens deeper into the sample, yielding progressively poorer images with depth. TruResolution objectives solve this challenge with an autocorrection collar. The system can be driven either by an algorithm that finds the best collar setting at each layer of a z-stack or by user-defined manual presets to deliver consistently bright and sharp images through out the captured volume.

### TruResolution Objectives



**FV30-AC10SV**  
10X multi-immersion  
NA 0.6, W.D. 8mm

**FV30-AC25W**  
25X water-immersion  
NA 1.05, W.D. 2mm

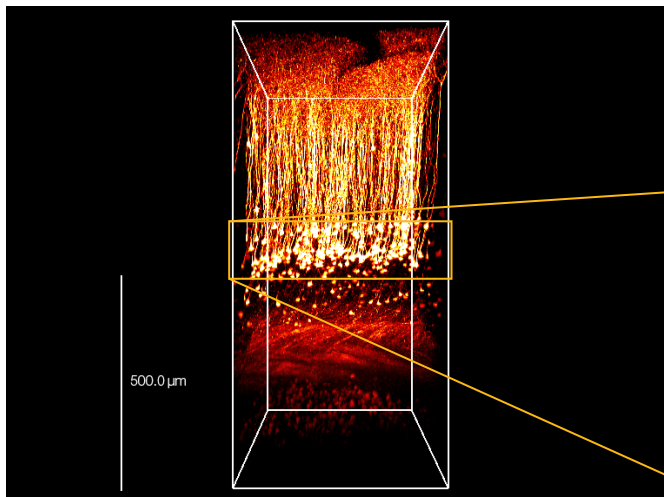

3D reconstructed image of mouse *in vivo* brain (Thy1-YFP-H mouse, sensory cortex) acquired by using TruResolution objective with auto adjustment function. Image data courtesy of: Dr. Hiromu Monai, Dr.Hajime Hirase and Dr. Atsushi Miyawaki, RIKEN BSI-Olympus Collaboration Center.

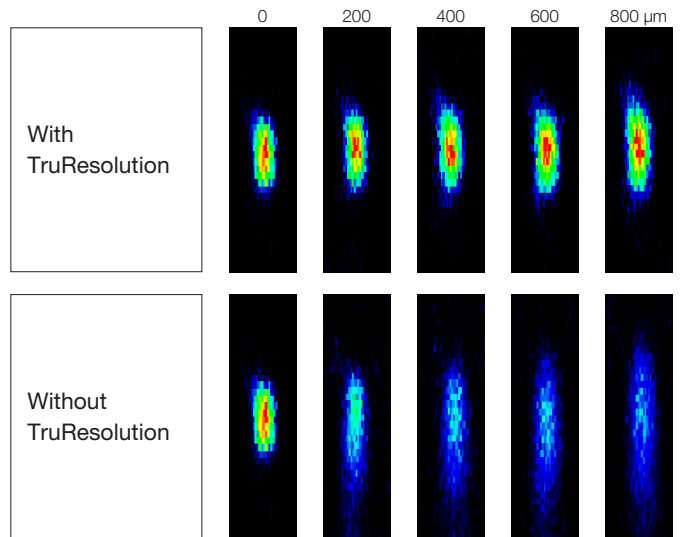

XZ images of 0.2μm fluorescent micro spheres in scattering gel (RI=1.36) at various depth acquired by using FV30-AC25W.

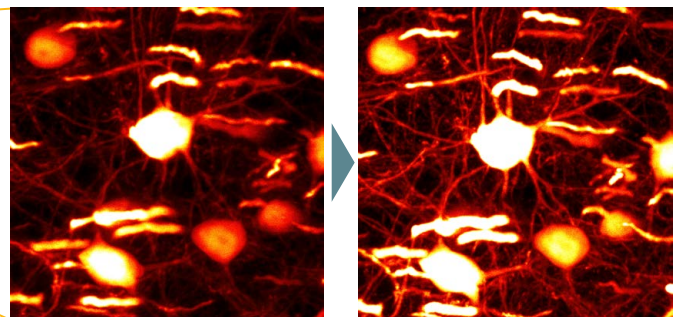

Without TruResolution

With TruResolution

Maximum projection of images acquired at around 600μm depth. Image data courtesy of: Dr. Hiromu Monai, Dr.Hajime Hirase and Dr. Atsushi Miyawaki, RIKEN BSI-Olympus Collaboration Center.

## Maximize Signal with Deep Focus Mode

Deep focus mode adjusts the diameter of the laser beam based on the laser scattering conditions. For *in vivo* specimens with heavy laser scattering, the beam is narrowed so that more excitation photons reach deeper within your sample, helping produce bright, high-resolution images.

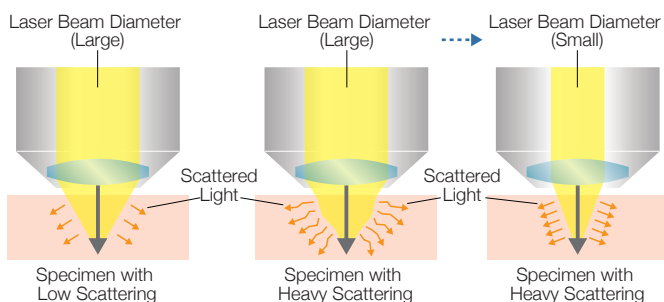

Both maximum intensity projection from 23 slices,  
Deep Focus Mode improves image brightness

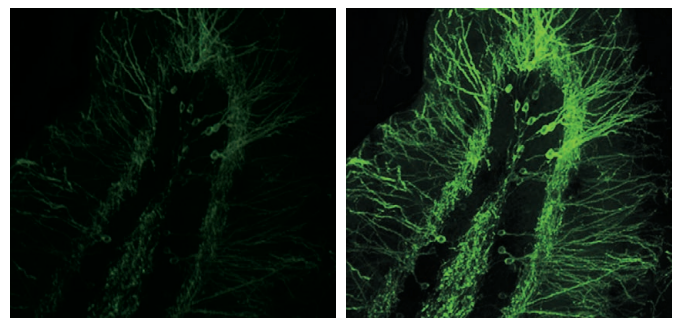

Normal image

Deep Focus Mode image

Image data courtesy of: Urs Ziegler and Jose Maria Mateos, Center for Microscopy and Image Analysis, University Zurich. Mouse line L15 kindly provided by Pico Caroni, FMI, Basel

## Observe *In Vivo* and Cleared Tissue Specimens Up to 8 mm Deep

Olympus dedicated multiphoton objectives are optimized for deep imaging under *in vivo* and cleared tissue conditions. A diverse lineup provides you the opportunity to select an objective according to your research requirements. Different optical designs emphasize high numerical aperture, long working distance, wide field of view, and compatibility with a range of immersion media and tissue clearing agents.

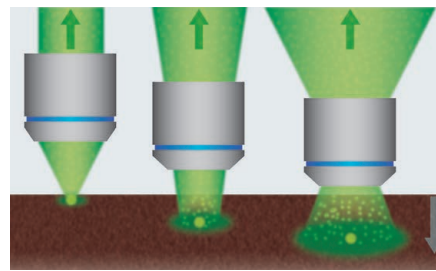

**Wide Field of View**  
Wide fields of view enable these objectives to efficiently collect scattered fluorescence photons and generate brighter images from deep within turbid specimens.

Dedicated Multi Photon Objectives	NA	W.D.(mm)	Immersion Index
<b>XLPLN10XSVM</b>	0.6	8.0	1.33–1.52
<b>XLPLN25XWMP2</b>	1.05	2.0	1.33
<b>XLPLN25XSVM2</b>	1.00	4.0	1.33–1.40
<b>XLSLPLN25XSVM2</b>	0.95	8.0	1.33–1.40
<b>XLSLPLN25XGMP</b>	1.00	8.0	1.41–1.52



**XLPLN10XSVM**  
W.D. 8mm



**XLPLN25XWMP2**  
W.D. 2mm



**XLPLN25XSVM2**  
W.D. 4mm



**XLSLPLN25XSVM2**  
W.D. 8mm



**XLSLPLN25XGMP**  
W.D. 8mm

## Silicone Oil Immersion for Live Cell Imaging

The UPLSAPO30XSIR objective applies the efficient IR transmission coating of MPE dedicated objectives to a high numerical aperture silicone oil immersion objective. This combination makes the objective well-suited to multiphoton imaging of live cell specimens. The closer refractive index matching between silicone oil and live cells minimizes image distortion in the Z-direction and improves image brightness and resolution.

During time-lapse imaging, the refractive index of silicone oil remains constant, and the oil does not dry out, minimizing the amount of time researchers need to spend tending the experiment.



### Silicone Immersion Objective UPLSAPO30XSIR

Magnification: 30x  
NA: 1.05 (silicone immersion oil)  
W.D.: 0.8 mm  
Cover glass thickness: 0.13–0.19 mm  
Operation temperature: 23°C–37°C

## Refractive Index is Important with Deep Tissue Observation

### Water immersion objective

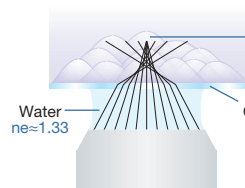

When working with a water immersion objective, the difference between the refractive index of the sample and water results in spherical aberration in deep tissue, causing resolution to deteriorate and fluorescence to become dim.

### Silicone immersion objective

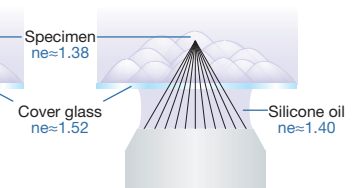

When working with a silicone immersion objective, the difference between the refractive index of the sample and silicone oil is minimal. So it achieves brighter fluorescence images with higher resolution for deep tissue observation.

## Visible to IR Transmission with Olympus 1600 Coating

Olympus multiphoton objectives and scanner optics have an optical coating that offers excellent transmission from 400 nm to 1600 nm. Efficient infrared transmission translates to more available power for fluorescence excitation at depth while strong support at short wavelengths maintains efficient collection of fluorescence and harmonic emissions.

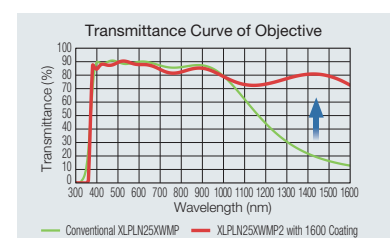

# Capture Fast, Dynamic Cellular Processes

## High-Speed, 438 Frames-per-Second Scanning

A fast resonant scanner and conventional galvanometer scanner provide high-speed and high-resolution imaging in a single system. Avoid motion artifacts when imaging dynamic samples with capture rates of 30 fps at  $512 \times 512$  pixels at the full field of view (FN 18) or up to 438 fps at  $512 \times 32$  pixels. These speeds enable applications such as tracking of fast moving cells in blood flow, and observing rapid membrane potential dynamics across neurons and other cells.

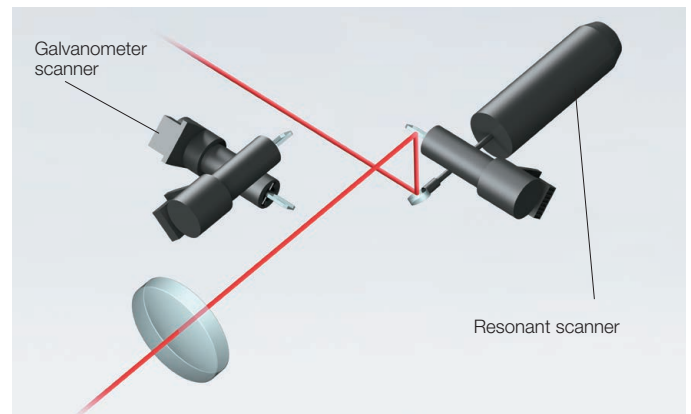

High speed imaging

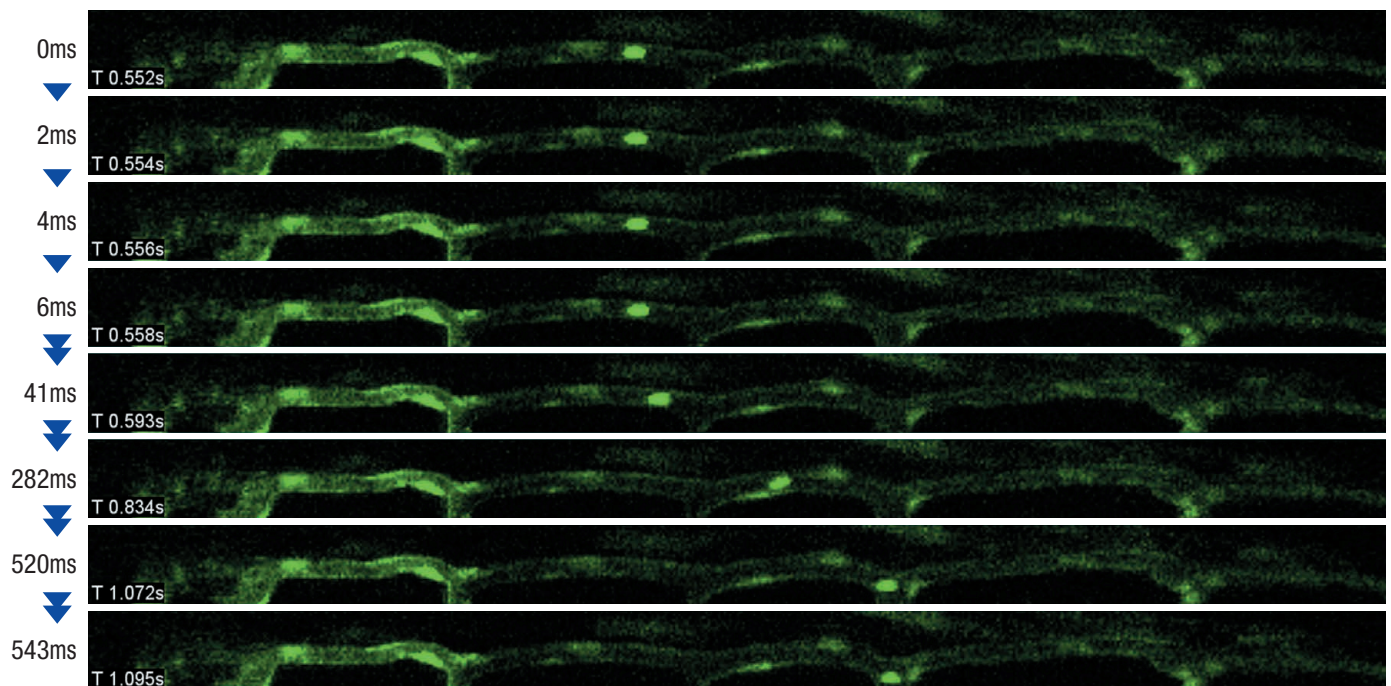

## Efficient Laser Transmission

Olympus silver-coated scanner mirrors help deliver more laser power to your sample to better excite fluorescence, and yield brighter images. The silver-coated mirrors achieve very high reflectance across a broad wavelength range, from visible to near infrared. The total reflectance for the XY scanner is particularly improved in the near infrared range compared to conventional aluminum-coated mirrors. The increased reflectance helps maximize available laser power and deliver the power needed for deep *in vivo* experiments.

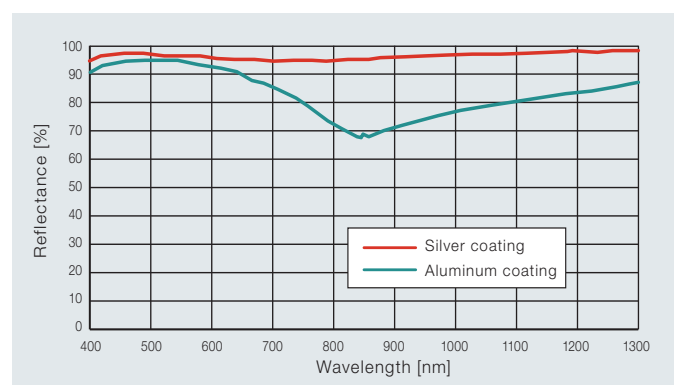

## A Cooled, High-Sensitivity GaAsP Detector Acquires High S/N Images

High signal-to-noise ratio imaging can be acquired even from faint fluorescence through the use of high sensitivity gallium arsenide phosphide (GaAsP) photomultiplier tube (PMT) detectors. — GaAsP PMTs deliver greater quantum efficiency than standard multialkali PMTs. Fan-less Peltier cooling further improves the signal-to-noise ratio. You can also leverage the advantages of both detector types by combining them in a single system.

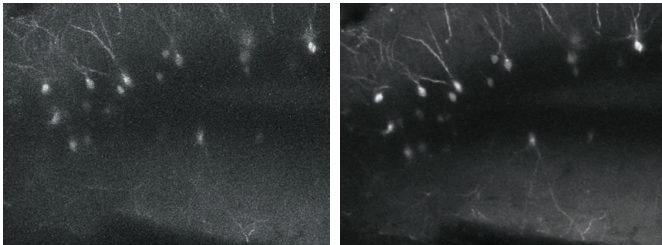
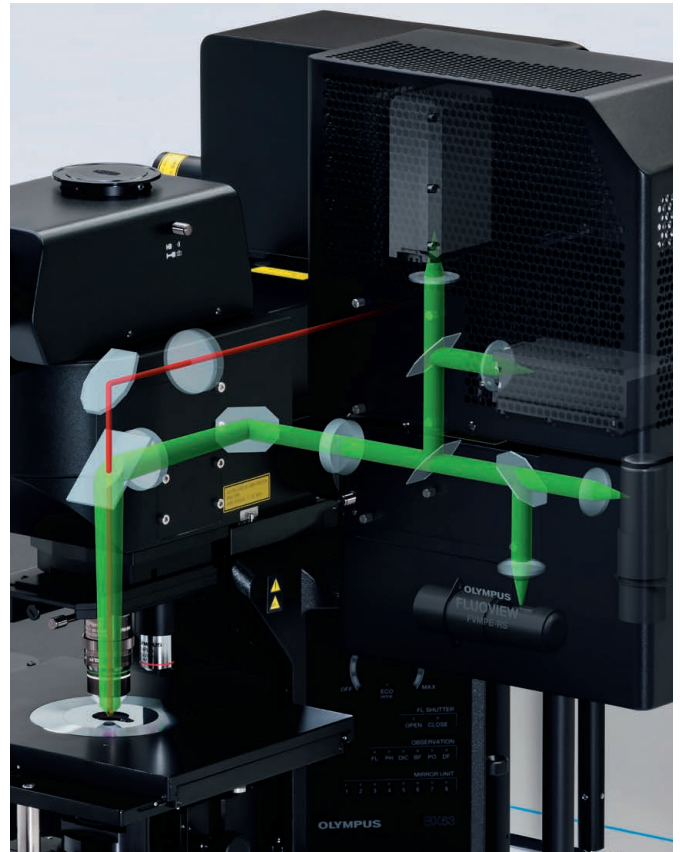

Image captured with multialkali detector    Image captured with GaAsP detector  
Arc-dVenus transgenic mouse (8-week-old), coronal brain block, hippocampal dentate gyrus  
Projection image of 300 — 400  $\mu\text{m}$  depth (5  $\mu\text{m}$  steps)

Image data courtesy of:  
Dr. Norio Takata, Dr. Hajime Hirase Laboratory for Neuron-Glia Circuitry, RIKEN BSI  
Dr. Shun Yamaguchi Gifu University Graduate School of Medicine

## Greater Fluorescence Capture

The non-descanned detection path has been designed for greater light efficiency—it is positioned close to the specimen and features large area optics to better capture scattered fluorescence photons.



## Microsecond Timing for Electrophysiology and Optogenetics

A hardware sequencer provides microsecond precision timing for stimulation and triggering events. Stimulation can be spatially and temporally synchronized to the imaging scan, facilitating the capture of fast response dynamics at precise locations. In the context of electrophysiology and optogenetics, this could mean the difference between distinguishing a synchronous versus an asynchronous stimulus response. For acquisitions lasting two weeks or longer or experiments with complex procedures that require switching between imaging tasks, the sequence manager software module maintains millisecond precision, providing high-quality data in demanding *in vivo* and *in vitro* experiments.

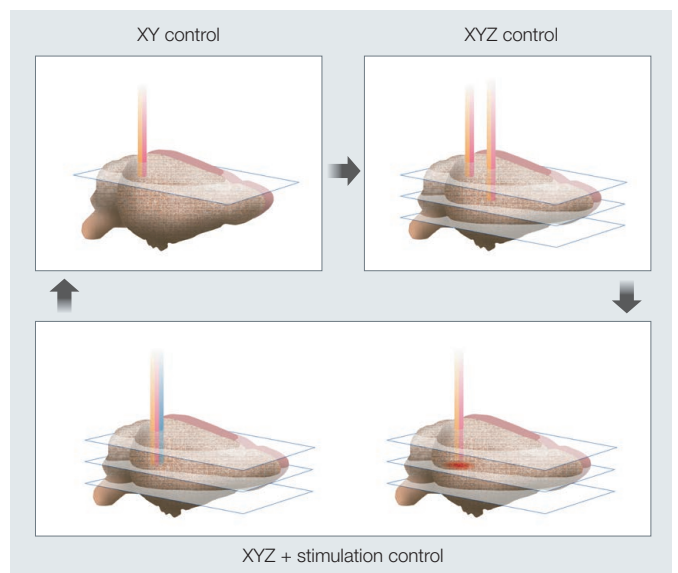

# Spend Less Time Tuning the Laser: Flexible Dual-Line Multiphoton Imaging

## Multiwavelength Excitation for Multiphoton Imaging

The FVMPE-RS imaging platform supports a dual wavelength infrared pulsed laser or two independent infrared lasers for multichannel, multiphoton excitation imaging. You can optimally excite different fluorophores without having to repeatedly tune the laser. Simultaneous excitation with independent power control of each laser line enables users to capture balanced images of different fluorophores. Separate excitation wavelengths for individual fluorophores can also reduce background tissue autofluorescence by shifting excitation away from the 800 nm range.

## Efficient Longer Wavelength Excitation

The InSight X3 pulsed IR laser by Spectra-Physics supports multiphoton imaging with tunable excitation from 680–1300 nm. The dual-line version adds a second fixed line at 1045 nm. With improved laser power beyond 1000 nm, the InSight X3 laser provides access to new multiphoton imaging capabilities. Utilize the growing library of red-shifted dyes and fluorescence proteins for deeper imaging or broader multichannel coverage. Perform third harmonic generation imaging in biological specimens without UV damage.

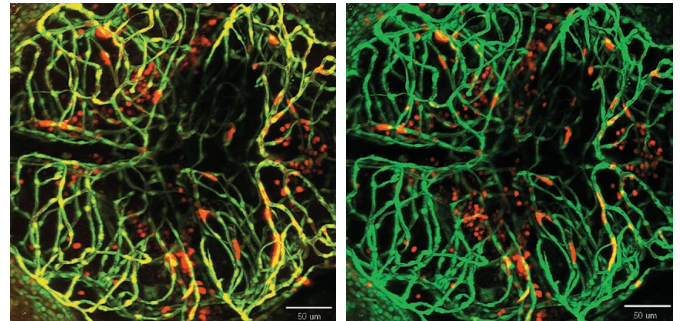

Crosstalk occurred after simultaneous excitation of GFP and DS-RED with a single wavelength IR pulsed laser (950 nm).

Two fluorescence proteins are clearly separated after individual excitation of GFP and DS-RED with a dual wavelength IR pulsed laser (950 nm/1040 nm).

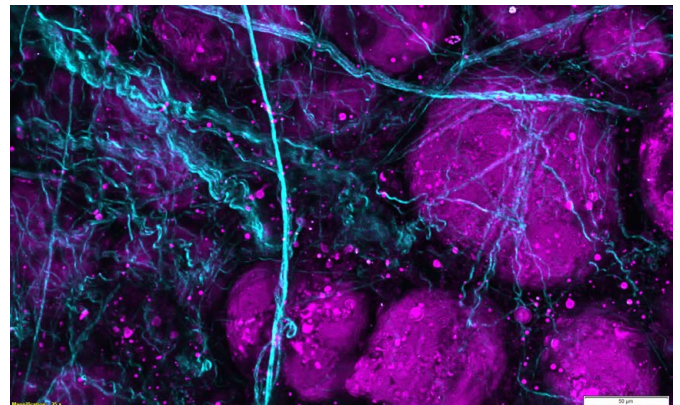

Third harmonic generation imaging of porcine adipose tissue. Unlabeled porcine adipose tissue was irradiated with femtosecond laser at 1250 nm, second harmonic is detected from collagen fibers at 625 nm and third harmonic from lipid interfaces at 416 nm.

## User-Friendly, Accurate Imaging with Auto Laser Alignment

Quadralign 4 axis laser alignment simplifies system upkeep by maintaining the precise alignment of the excitation beam into the scanner unit, even in the face of laser drift due to wavelength tuning, temperature fluctuation, and other sources of cavity shift. The beam position and angle are automatically adjusted to deliver higher laser power and consistent pixel registration. If your system has two excitation laser lines, this feature offers an additional benefit. Auto laser alignment maintains co-alignment between the beams, helping eliminate co-registration errors between channels. The laser alignment can also be manually fine-tuned using the software interface.

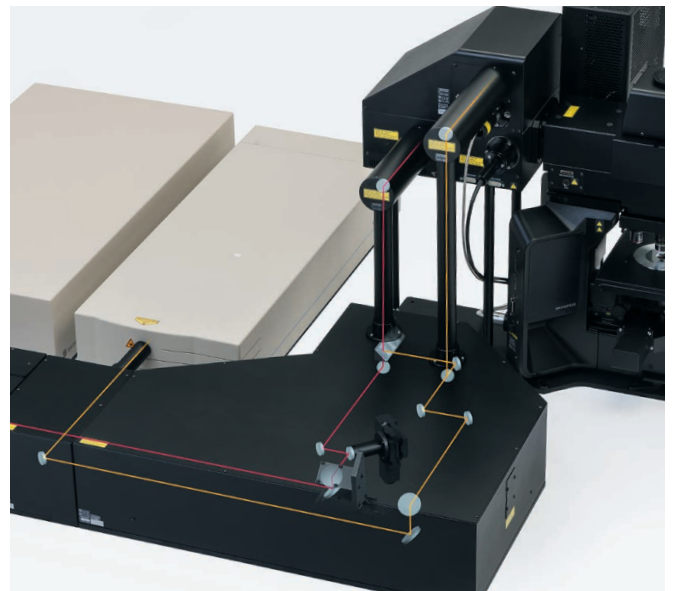
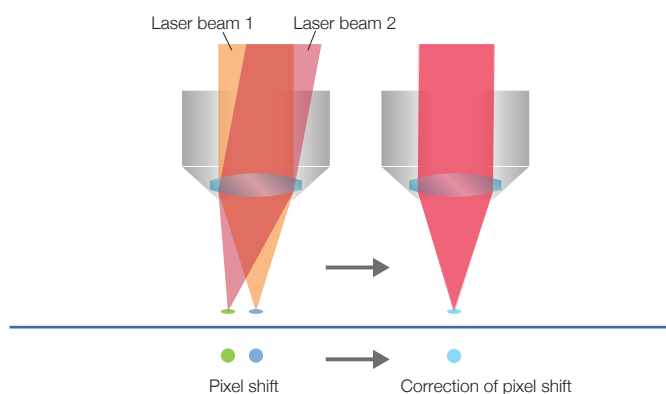

# Optional Features for Advanced Applications

## Simultaneous Multiphoton Stimulation and Imaging with the SIM Scanner

The SIM scanner, an independent galvanometer scanner, and visible laser modules can be added for precise microsecond photostimulation and photobleaching experiments. On systems with two IR imaging lines, the SIM scanner enables simultaneous multiphoton stimulation and imaging.

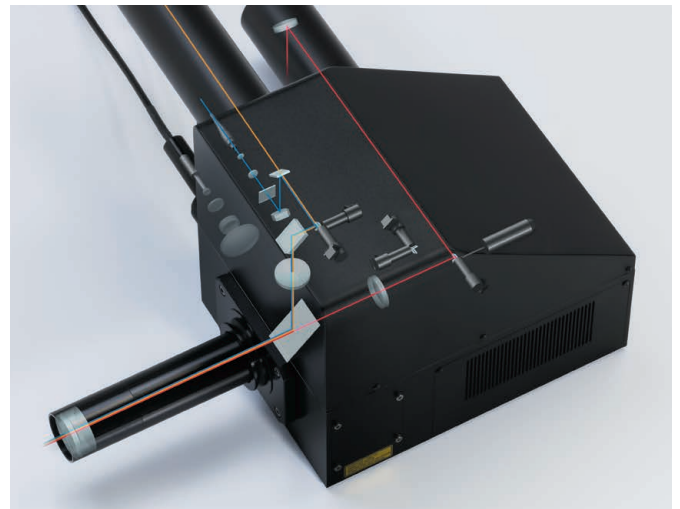

## Synchronize Electrophysiological Data and Laser Light Stimulation with the Analog Unit

Analog inputs and TTL I/O are available to support electrophysiology experiments. The analog input unit records external voltage signals as images that are treated the same way as normal image data. Light-stimulated electrical signals measured with patch clamps can be synchronized with image capture and displayed as a pseudocolor intensity overlay.

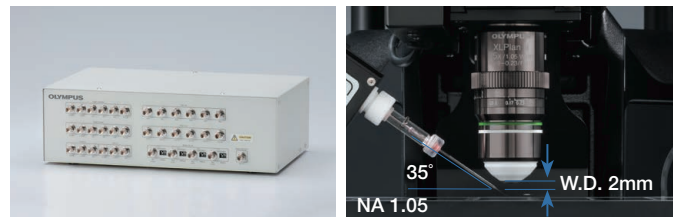

## Create 3D Stimulation Reaction Maps

To achieve highly targeted laser light stimulation, the observation field is divided into a grid, and the laser illuminates each area in a pseudorandom sequence that avoids sequential stimulation of adjacent areas. A stimulation reaction map is drawn based on patch clamp recording or imaging intensity. Integration of an optional piezo nosepiece extends the reaction map to 3D, with stimulation delivered at depths different from the imaging plane.

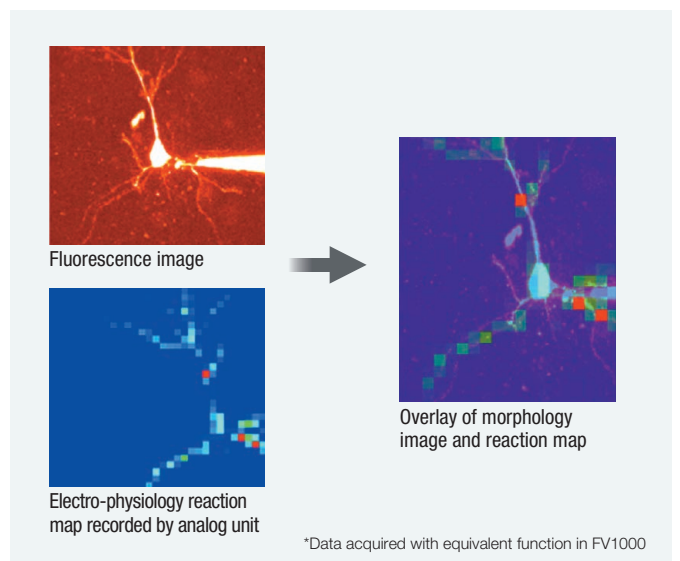
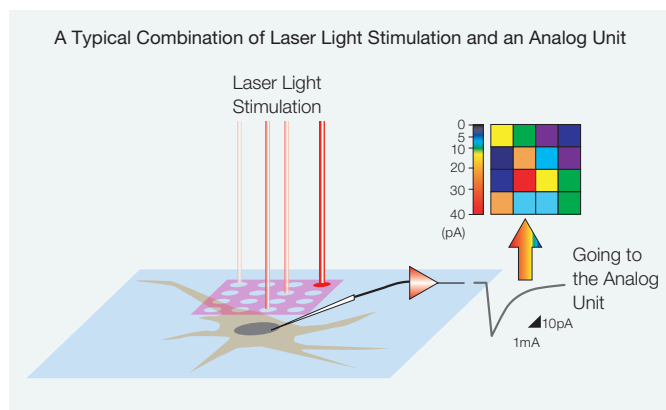
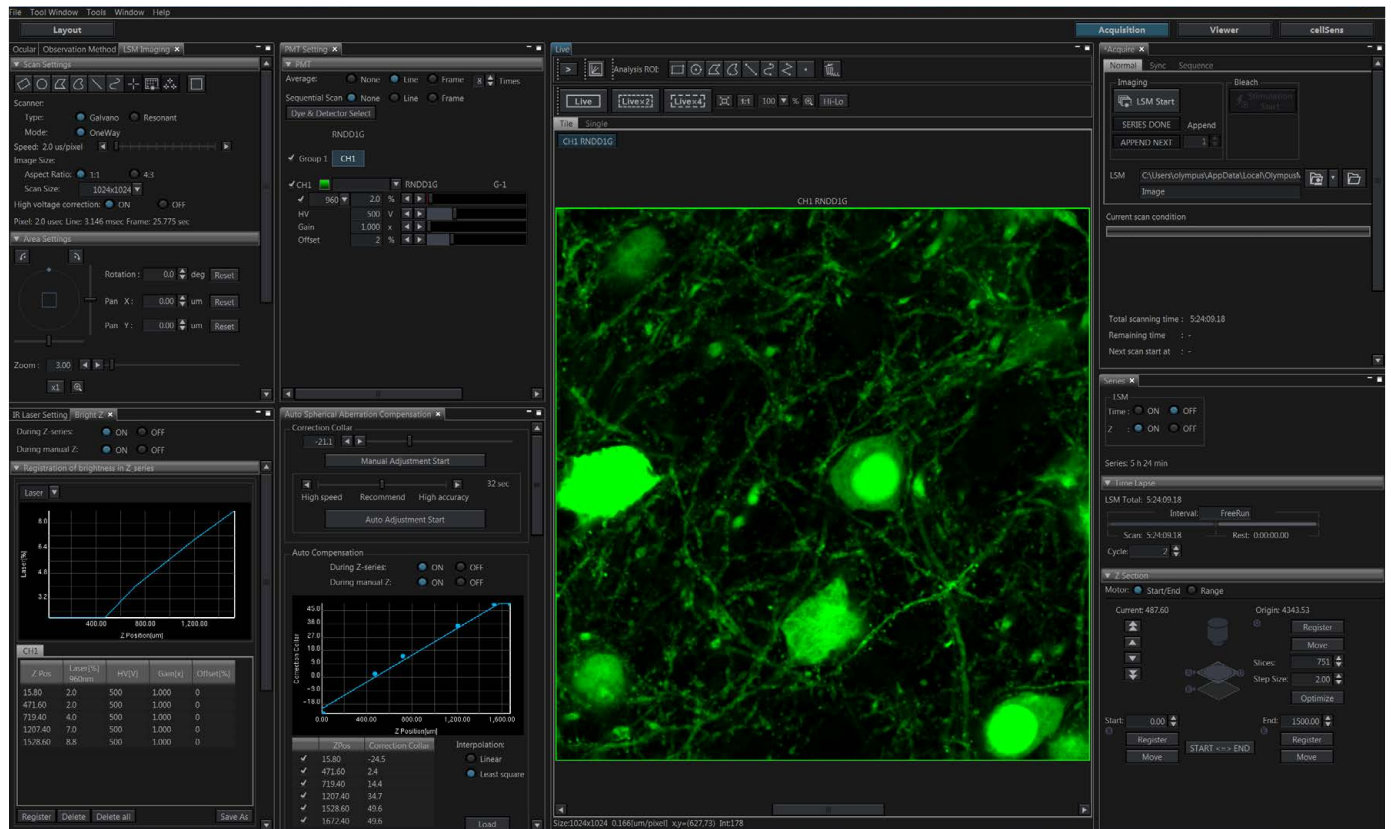

Image data courtesy of:  
Haruo Kasai  
Center for Disease Biology and Integrative Medicine, Faculty of Medicine,  
The University of Tokyo

# Intuitive Software Optimized for Multiphoton Observation



## 1. Layout

- Select the layout based on your experiment

## 2. Acquisition Conditions

- Reload the settings from previous experiments

## 3. Acquisition

- Acquire multidimensional images
- Acquire multiarea images
- Acquire images using a complex protocol

## 4. Viewer

- Review images during or after the acquisition using various display methods

## 5. Analysis

- Various image analysis tools are available
- Perform analysis via a one-click macro

## Customizable Layout

Customize which controls you see in the software interface and where they are located. Save and reload your favorite layouts.

## Save and Recall Settings

Save the acquisition parameters that you use during an experiment. The parameters can be easily recalled for repeatable imaging conditions.

## Precisely Control Your Experiments

The sequence manager makes it easy to coordinate experiments. Complex protocols, such as changing the frame rate during time-lapse imaging or repeating photostimulation events at different positions during image acquisition, can be organized and accurately carried out with precise timing. Protocols can also be saved and later reloaded for consistent execution of experiments.

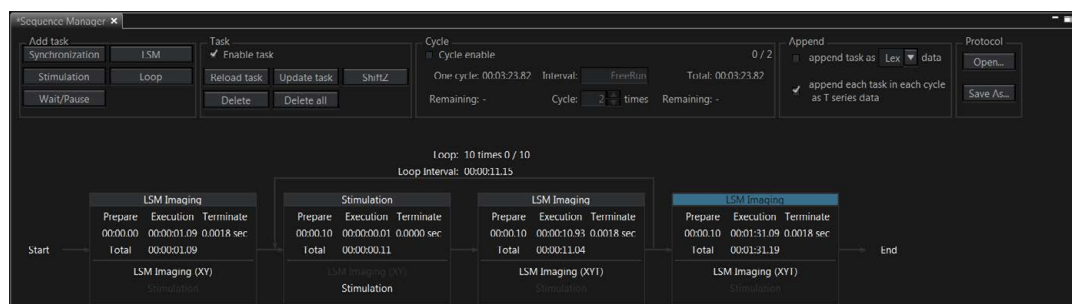

## Combine Wide Field of View with High Resolution

See your entire specimen at high resolution and in context with the tiling function. This software feature scans multiple adjacent images and stitches them together. With a motorized stage, images can be stitched together in a very wide field of view, while the mapping feature makes it easy to locate the position of specific cells in the larger image.

**Using the map function with motorized stage, finding target field of view is easy**

Image data courtesy of:  
Urs Ziegler and Jose Maria Mateos  
Center for Microscopy and Image Analysis, University Zurich  
Mouse line L15 kindly provided by Pico Caroni, FMI, Basel

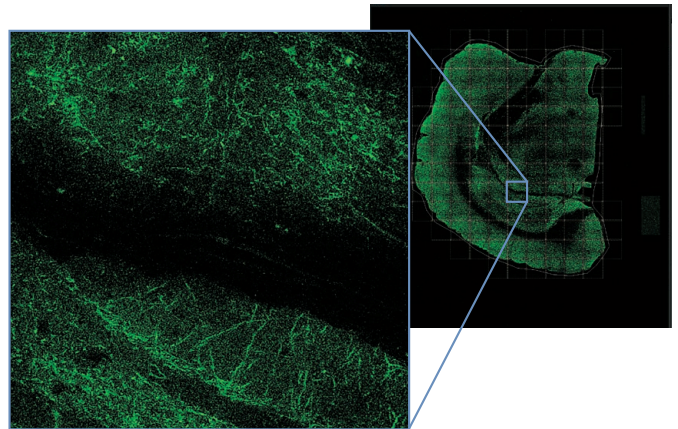

## Expanded Analysis Functions

The FVMPE-RS imaging platform's software is integrated with Olympus cellSens image analysis software, expanding the system's analytical capabilities. Optional features include 3D deconvolution for Z-stack images, area estimation for each particle in an image, an image processing filter, and colocalization analysis.

## Separate Overlapping Channels with Spectral Deconvolution

Closely overlapping fluorescence spectra can complicate biological studies that look at multiple labels simultaneously. Separation of overlapping spectral channels is possible via spectral deconvolution based on either a blind unmixing algorithm or previously saved multichannel profiles. Cross-talk between the channels can even be eliminated during image acquisition via live processing.

**Mouse kidney tissue stained with Alexa Fluor 488 WGA and Alexa Fluor 568 Phalloidin**

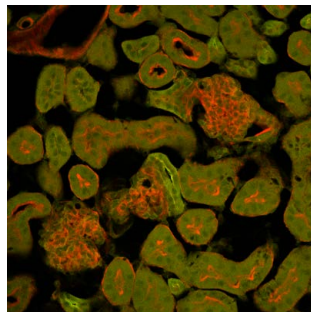

Normal mode

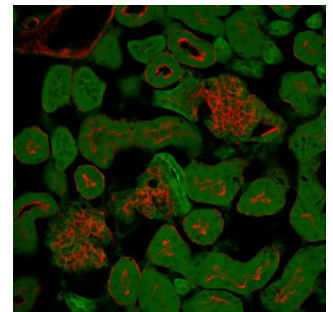

Live unmixing mode

## 3D Rendering

Large amounts of Z-stack data can be rendered into a 3D display. Important views can be registered as key frames, making it easy to create animated views of 3D images that zoom and transition to different camera angles.

**4 mm 3D stack on blood vessel label with Texas Red in mouse brain**

Image data courtesy of:  
Hiroshi Hama, Rie Ito, Atsushi Miyawaki  
Laboratory for Cell Function Dynamics, RIKEN Brain Science Institute

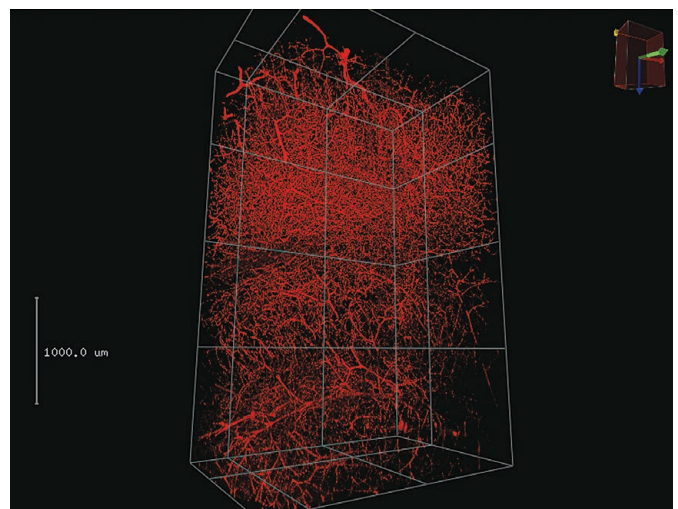

# Choose From 3 Frames and 3 Laser Configurations

## Designed for Multiphoton Microscopy Upright Microscope System

- Non-descanned detectors are sensitive to ambient light, and the black microscope frame helps reduce undesired light reflections.
- A large focus stroke accommodates a range of specimens, from tissue slices to live mice and other small animals.
- The optional transmitted fluorescent light detector expands the system's capabilities in multiphoton imaging. The high NA condenser efficiently collects transmitted fluorescence as well as transmitted second and third harmonic generation signals.
- The motorized fluorescence illuminator has a double deck design to reduce vibration during mirror unit exchange. It's easy to change observation conditions (multiphoton and widefield fluorescence), even during simultaneous patch clamp experiments.

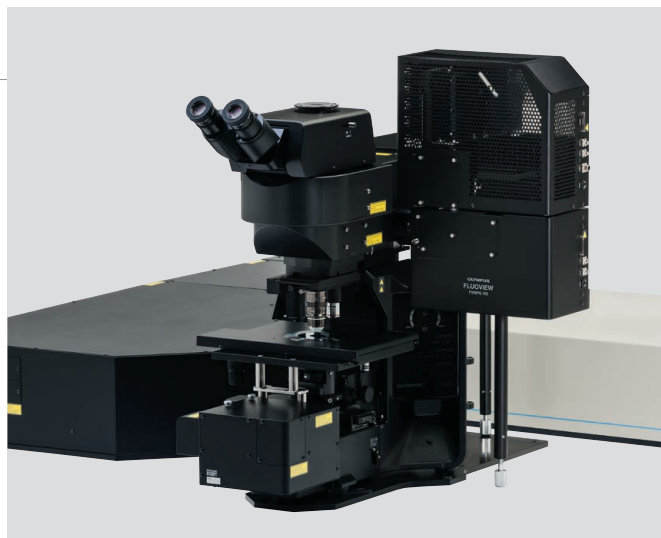

## For *in vivo* Observation that Require Maximum Space Gantry Microscope System

- A removable, manual XYZ stage enables height adjustments. Changing from thin sample to whole animal imaging is quick and easy.
- The frame maintains a large working space beneath the objective, making it easier to position experiment equipment.

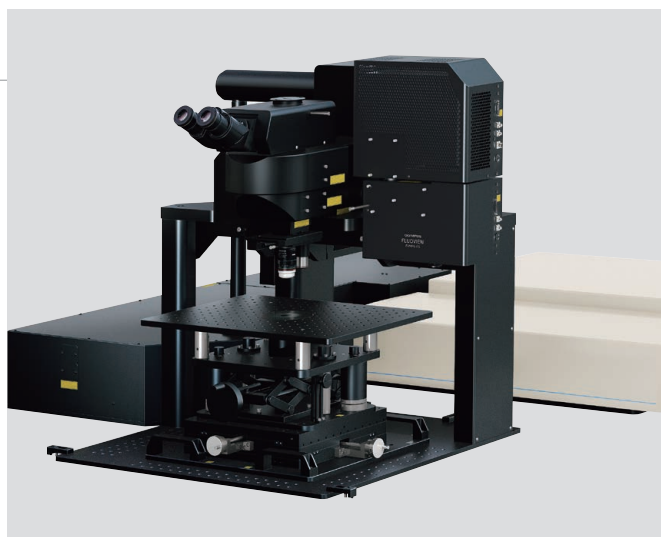
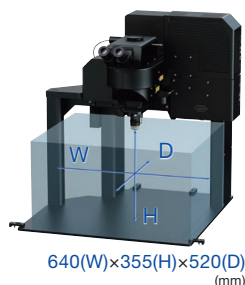

## For Observing Tissue Cultures, 3D Cultures, and Cell Cultures (Spheroid) Inverted Microscope System

- The frame supports observations of 3D cultures and multicellular clusters that are difficult to image using an upright frame.
- The optical performance of the Olympus IX83 fully automated microscope was optimized to efficiently collect scattered fluorescence light. Non-descanned detection performance is improved compared to previous multiphoton systems on inverted frames.



### One Laser System

This streamlined system uses a single multiphoton infrared laser for imaging. Add an optional SIM scanner for visible laser stimulation.

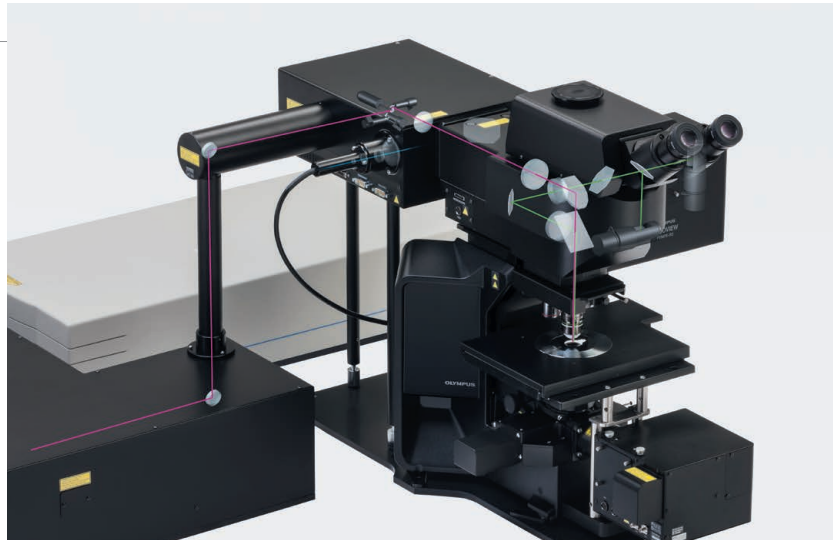
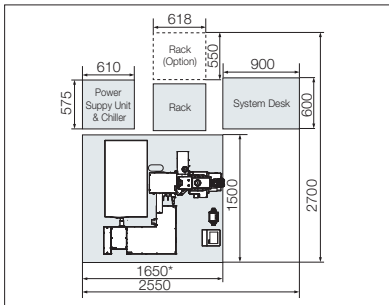

### Dual Laser Lines System

This system supports dual wavelengths for multiphoton, multicolor imaging. Add an optional SIM scanner for visible laser stimulation and simultaneous multiphoton stimulation at 1045 nm.

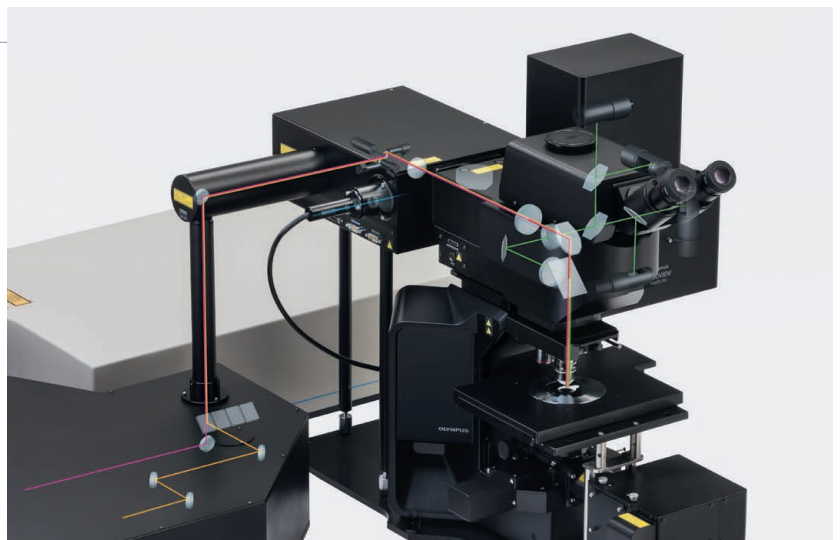
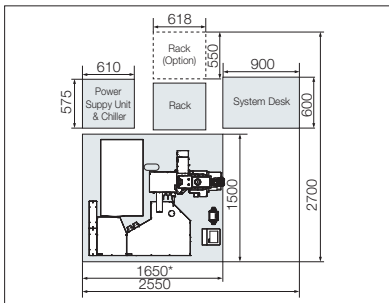

### Twin Lasers System

This flexible system employs two multiphoton infrared lasers for imaging. In addition to multiphoton, multicolor imaging, visible laser stimulation and simultaneous multiphoton stimulation across tunable wavelengths is also supported in combination with an optional SIM scanner.

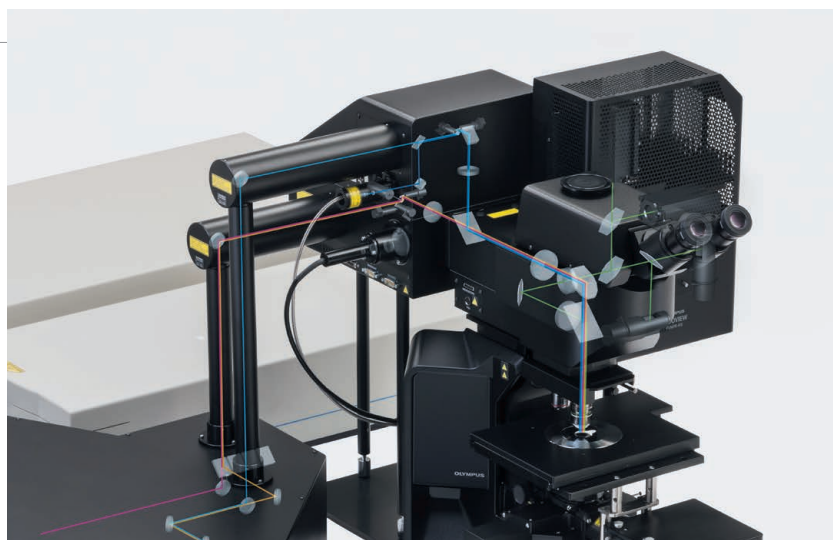
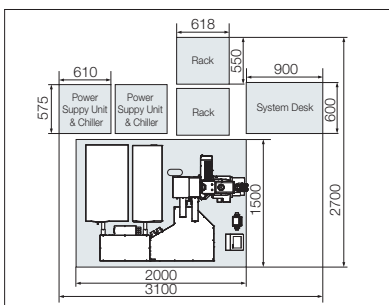

# Modular Units Designed for Your Applications

## Lasers for Multiphoton Configurations

The InSight X3 Dual-OL laser enables dual wavelength, simultaneous imaging for deep observation. It has a high peak power with short, 120 fs pulse widths, a broad continuously tunable range from 680 nm to 1300 nm, and a fixed wavelength line at 1045 nm. A selection of other models are available to match your multiphoton excitation requirements.



Manufacturer	Model	Wavelength covered
Spectra-Physics	MAITAI HPDS-OL	690 nm — 1040 nm
	MAITAI eHPDS-OL	690 nm — 1040 nm
	INSIGHT X3-OL	680 nm — 1300 nm
	INSIGHT X3 DUAL-OL	680 nm — 1300 nm
	INSIGHT X3 DUALC-OL	1045 nm (fixed)

Manufacturer	Model	Wavelength covered
COHERENT	Chameleon Vision I Olympus	690 nm — 1040 nm
	Chameleon Vision II Olympus	680 nm — 1080 nm
	Chameleon Vision S Olympus	690 nm — 1050 nm

\*Chameleon Series of lasers are not available from Olympus in some regions.

## Visible Beam Combiner for Laser Light Stimulation

The laser combiner enables solid-state laser combinations for laser light stimulation at wavelengths of 405 nm, 458 nm, and 588 nm.



## Light Guide Illumination Source (U-HGLGPS)

This light source is equipped with a liquid light guide that minimizes the impact of vibration and lamp heat on both the microscope and specimens. With a metal-halide bulb, the light source offers an average lifetime of 2000 hours.



## Transmitted Non-descanned Light Detector

A high NA condenser and transmitted non-descanned light detector for multiphoton imaging detect fluorescence and harmonic emissions scattered in the forward direction from the sample plane.

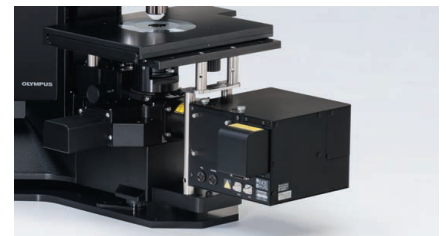

## Reflected Non-descanned Light Detector



### Multialkali PMT 2CH Detector

This basic multialkali 2CH PMT provides robust performance across a wide range of wavelengths.

### Multialkali PMT 4CH Detector

Expand your simultaneous detection capability with a total of 4 multialkali PMTs.

### Cooled GaAsP PMT 2CH Detector

This Peltier-cooled 2CH GaAsP PMT provides higher sensitivity for weak signals or short pixel dwell times.

### Multialkali PMT 2CH + 2CH Cooled GaAsP PMT Detector

Combine the robustness and dynamic range of multialkali PMTs with the high sensitivity of GaAsP PMTs.

## FLUOVIEW FVMPE-RS SPECIFICATIONS

		One Laser System	Dual Lines System	Twin Lasers System
<b>Unit</b>	Qualified IR pulsed lasers with negative chirp for multi photon excitation	<ul style="list-style-type: none"> <li>Spectra-Physics products :                             <ul style="list-style-type: none"> <li>MAITAI HPDS-OL: 690 nm — 1040 nm</li> <li>MAITAI eHPDS-OL: 690 nm — 1040 nm</li> <li>INSIGHT X3-OL: 680 nm — 1300 nm</li> <li>INSIGHT X3 DUAL/DUALC-OL: 680 nm — 1300 nm + 1045 nm</li> </ul> </li> <li>Coherent products:                             <ul style="list-style-type: none"> <li>Chameleon Vision I Olympus : 690 nm — 1040 nm</li> <li>Chameleon Vision II Olympus : 680 nm — 1080 nm</li> <li>Chameleon Vision S Olympus : 690 nm — 1050 nm</li> </ul> </li> </ul>		
	Main IR pulsed laser	MAITAI HPDS-OL MAITAI eHPDS-OL INSIGHT X3-OL Chameleon Vision I Olympus Chameleon Vision II Olympus Chameleon Vision S Olympus	INSIGHT X3 DUAL-OL INSIGHT X3 DUALC-OL	MAITAI HPDS-OL MAITAI eHPDS-OL INSIGHT X3-OL Chameleon Vision I Olympus Chameleon Vision II Olympus Chameleon Vision S Olympus
	Additional IR line Laser: Use as second imaging line/ laser or for simultaneous stimulation (optional SIM scanner)		1045 nm fixed line from INSIGHT X3 DUAL / DUALC-OL	MAITAI HPDS-OL MAITAI eHPDS-OL Chameleon Vision I Olympus Chameleon Vision II Olympus Chameleon Vision S Olympus
	Automatic Introduction Optic	Introduction optic with AOM attenuation (0% — 100%, 0.1% increment) Including fully automated beam expander, XY shifter and two axes angle alignment. (4 Axes Quadralign Auto Alignment optic) Direct coupling to laser port of scanning unit.		Introduction optic with 2 sets of AOM attenuation (0% — 100%, 0.1% increment) Including 2 sets of fully automated beam expander, XY shifter and two axes angle alignment. (4 Axes Quadralign Auto Alignment optic) Direct coupling to laser port of scanning unit.
	IR laser combining optic			Motorized light path switcher, with DM900, DM1000R, DM1100 to combine two IR wavelength for imaging.
	Optional Visible light laser for stimulation	405 nm/50 mW, 458 nm/20 mW, 588 nm/20 mW laser source with AOTF attenuation. 0% — 100%, 0.1% increment, < 2 μs rising time		
<b>Scanning Unit</b>	Scanning Method	Light deflection via 2 silver-coated galvanometer scanning mirrors, or silver-coated resonant scanning mirror.		
	Scanning Speed	Galvanometer Scanner (Normal Imaging) : 512 × 512 with 1.1 s — 264 s. Pixel time : 2 μs — 1000 μs. Resonant Scanner (High Speed Imaging) : 30 fps at 512 × 512, 438 fps at 512 × 32		
	Scanning Mode	XY, XYZ, XYT, XYZT, free line, XZ, XT, XZT, PointT		
	Galvanometer Scanner (Normal Imaging)	Galvanometer ROI scanning: Rectangle Clip, Ellipse, Polygon, Free Area, Line, FreeLine & Point. Zoom: 1.0× — 50.0× with 0.01× increment, support 0° — 360° rotation and pan Scanning Field Number: 18 Image Size: 64 × 64 — 4096 × 4096		
	Resonant Scanner (High Speed Imaging)	Resonant ROI scanning: Rectangle Clip, Line. Zoom: 1.0× — 8.0× with 0.01× increment Scanning Field Number: 18 Image Size: 512 × 512		
	Optical Coating	IR support optic with 1600 Coating.		
	Non Descanned MPE imaging detectors	Reflected detection: 2 or 4 channel configuration: 2 PMTs configuration, 4 PMTs configuration or 2 PMTs + 2 cooled GaAsP-PMTs Transmitted detection: 2 PMTs unit with high NA condenser.		
	Transmitted light detector	Module with integrated external transmitted light photomultiplier detector and 100 W Halogen lamp, motorized switching, fiber adaptation to microscope frame		
	Z-Drive	Integrated motorized focus module of the microscope, minimum increment 0.01 μm Optional: highly rigid piezo nosepiece*1		
	Optional Simultaneous Stimulation Scanner	Highly synchronized simultaneous stimulation scanner, including a set of Galvanometer Scanner, VIS and IR laser port. ROI scanning: Rectangle Clip, Ellipse, Polygon, Tornado, Free Area, Line, FreeLine & Point.		
Optional analog and digital in out box	4 channels analog signal input, 6 channels digital TTL trigger input, 5 channel digital TTL trigger output. Scanner timing output			
<b>MPE Objective with Auto Spherical Aberration Compensation Function</b>	FV30-AC10SV	MAG.: 10X, NA: 0.6, W.D.: 8mm, Immersion Medium: SCALEVIEW-A2 (Water, Silicone oil and Normal oil available)		
	FV30-AC25W	MAG.: 25X, NA: 1.05, W.D.: 2mm, Immersion Medium: Water		
<b>Operation Environment</b>	Room temperature: 20 — 25°C, humidity: 75% or less at 25°C, requires continuous (24-hour) power supply			
<b>Size of Anti-vibration table</b>	1500 mm × 1650* mm *1800 mm with Inverted Microscope System	1500 mm × 1650* mm *1800 mm with Inverted Microscope System	1500 mm × 2000 mm	
<b>Software</b>	Basic Feature	Dark room matching GUI design. User arrangeable layout. Acquisition parameter reload features. Hard disk recording capability, Adjust laser power and HV with Z-Stack acquisition. Z-Stack with alpha blending, Maximum intensity projection, Iso-Surface rendering		
	IR laser controlling	Fully integrated IR laser wavelength control and Deep Focus Mode		
	Optional Motorized Stage software	XY motorized stage control, Map image acquisition for easy target locating. Tiling acquisition and software image stitching. Define multiple area for time lapse imaging.		
	Optional Mapping and Multiple point stimulation software	Multiple point stimulation and data acquisition software. Mapping multiple point stimulation to generate reaction map. Filtering feature to select points. Multiple point stimulation. Single or repeat stimulation. Each point independent stimulation wavelength selection.		
	Optional Sequence Manager	Advanced programmable software to define multiple imaging/stimulation tasks and execute by hardware sequencer. Minimum gap 100 ms delay between tasks.		
Optional Auto Compensation software	Automatic spherical aberration compensation software. Control of objective lens with auto spherical aberration compensation function. Auto adjustment of motorized correction collar to find the best position at certain observation depth. Auto adjustment of correction collar along with Z movement.			

\*1 Not available in some areas.

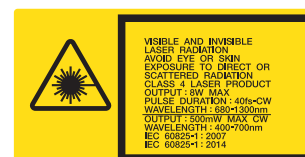

Image data on cover page: YFP-H mouse Brain of 20 weeks old treated by Sca/eS  
Courtesy of:  
Hiroshi Hama, Atsushi Miyawaki  
Laboratory for Cell Function Dynamics RIKEN Brain Science Institute

- **EVIDENT CORPORATION is ISO14001 certified.**
- **EVIDENT CORPORATION is FM553994/ISO9001 certified.**
- **Illumination devices for microscope have suggested lifetimes. Periodic inspections are required. Please visit our website for details.**

- This product is designed for use in industrial environments for the EMC performance. Using it in a residential environment may affect other equipment in the environment.
- All company and product names are registered trademarks and/or trademarks of their respective owners.
- Images on the PC monitors are simulated.
- Specifications and appearances are subject to change without any notice or obligation on the part of the manufacturer.

[EvidentScientific.com](http://EvidentScientific.com)



**EVIDENT CORPORATION**  
Shinjuku Monolith, 2-3-1 Nishi-Shinjuku, Shinjuku-ku, Tokyo 163-0910, Japan